

How to Order a PPU30/45?

Each unit is made to order and its mounting is custom made to match your particular conveyor dimensions. On this basis, it is a great advantage if you can provide us with a step model of your conveyor system.

When you contact Pulseroller to place an order for the part number you want, we will need to know the following additional information to complete your order:

Conveyor Dimensions *(Please give all dimensions in mm)*

- A** Conveyor Between Frame (BF)
- B** Height of Conveyor Frame
- C** Width of bottom flange of conveyor frame
- D** Width of opposite conveyor frame flange (if different from C)
- E** Distance from top of conveyor frame to top of roller
- F** Roller diameter 50mm or 54mm
- G** Roller center pitch
- H** Distance from centerline of 1st PPU Lifting Unit to centerline of bottom frame flange mounting hole¹
- J** Distance from centerline of 2nd PPU Lifting Unit to centerline of bottom frame flange mounting hole¹
- K** Distance from edge of bottom flange to centerline of mounting holes¹
- L** Motor/Control - Specify Senergy (JST) or Senergy-Ai (M8 - 4Pin)²
- M** Interlocking - Specify if your conveyor has Micro-V or Grooves with O-Bands.
- N** Minimum and maximum dimensions of the conveyed goods and maximum weight of the conveyed goods

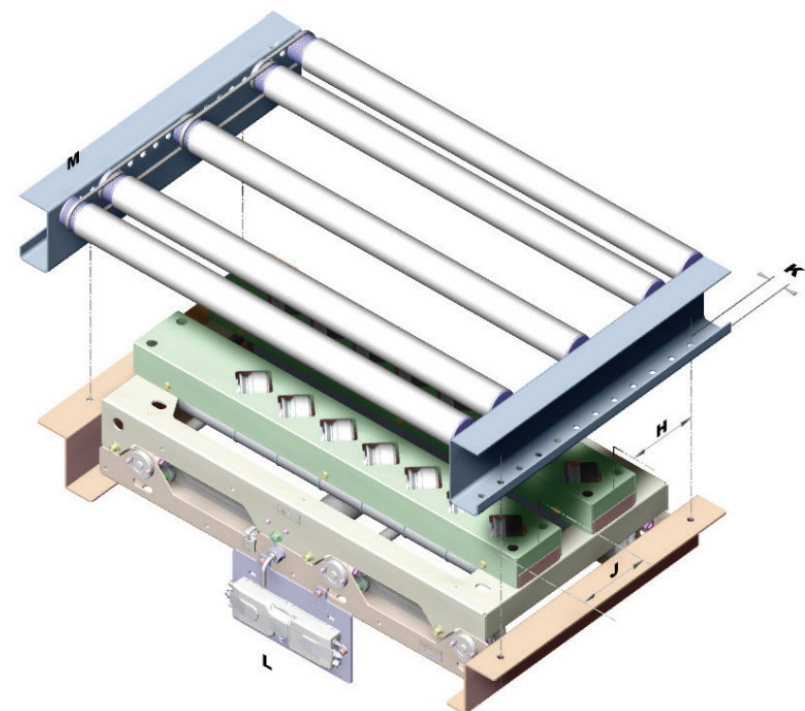
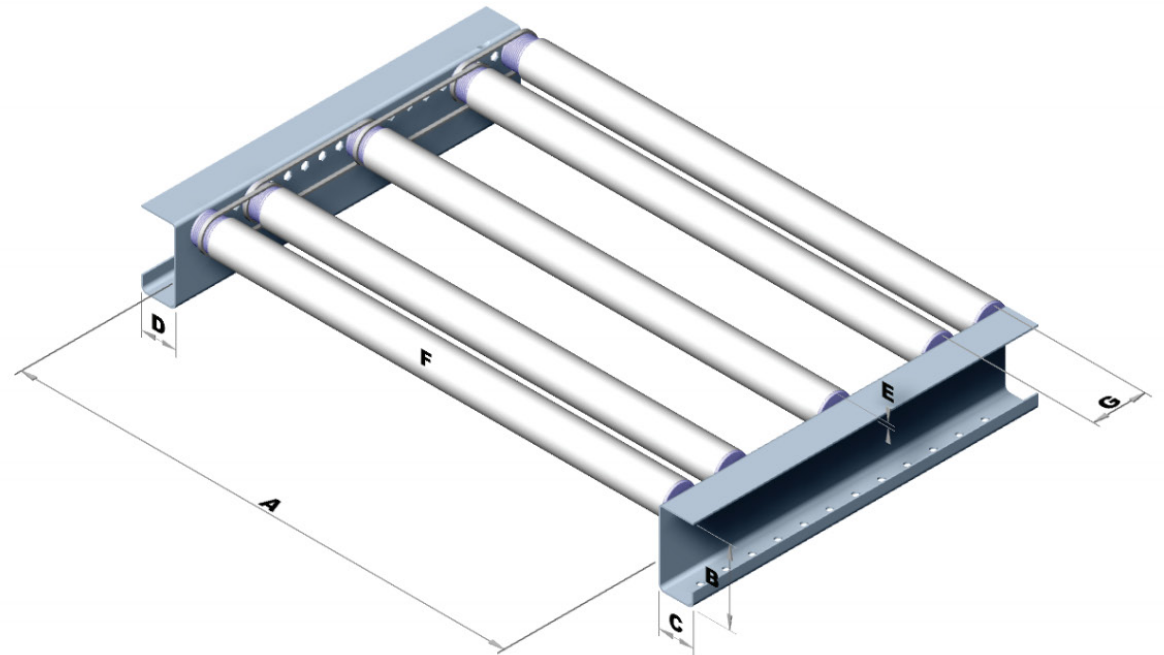

Mounting Considerations

Area under PPU30/45 has to be free of any conveyor supports or cross-members.

¹ Irregular mounting hole pitches and locations may be accommodated. Contact us for details.

² For Senergy-Ai motor rollers, you can specify ConveyLinx-Ai2 or MotionLinx-Ai controllers.